

RECKMANN

Instructions for use

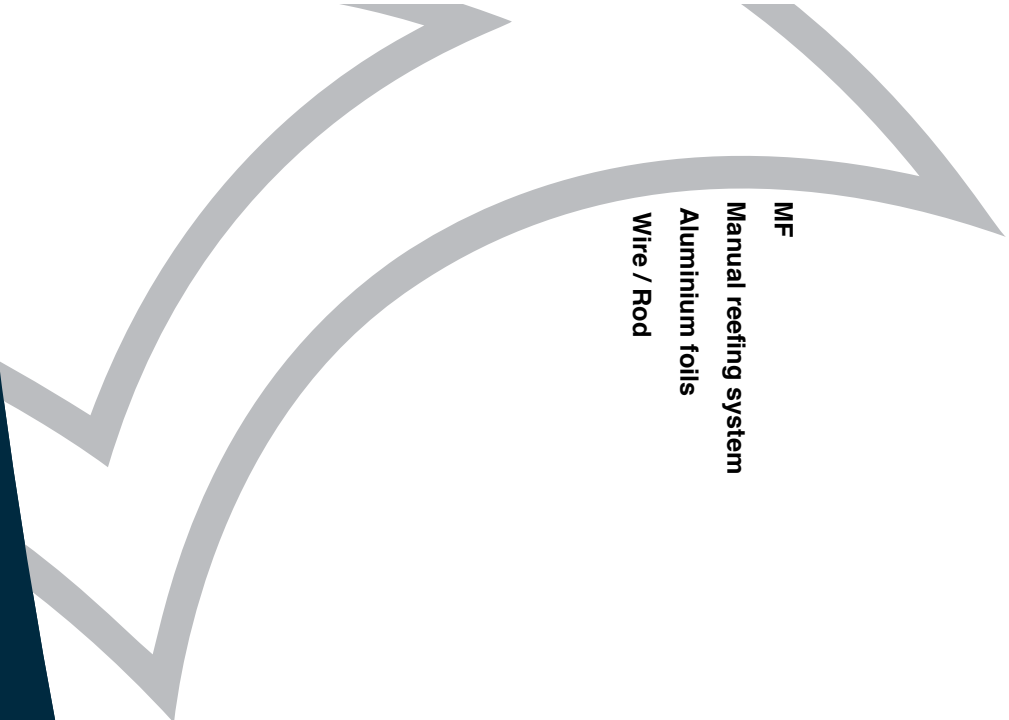

MF
Manual reefing system
Aluminium foils
Wire / Rod

Reckmann Yacht Equipment GmbH

Siemensstr. 37-39
25462 Rellingen
Germany
Tel: +49(0) 4101 3849-0
Fax: +49(0) 4101 3849-50
info@reckmann.com
www.reckmann.com

Revised: 2016-08-04

© Reckmann Yacht Equipment GmbH
Siemensstr. 37-39
25462 Rellingen
Germany

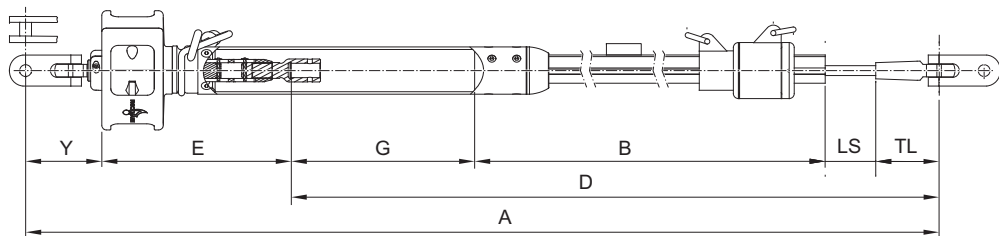

Calculating the forestay length				
D =	A	-	E	Y
D =	_____	-	_____	_____
D =	_____ mm			

Calculating the furling section length					
B =	D	-	TL	LS	G
B =	_____	-	_____	_____	_____
B =	_____ mm				

[mm]	LS	Rod	G*	Wire	Rod	E*	Wire	Y**
M/F-1	70	140	∅ 6, 7, 8: 138 ∅ 10: 126	272	∅ 6, 7, 8: 274 ∅ 10: 286	100		
M/F-2	70	172	∅ 10: 159 ∅ 12: 164 ∅ 14: 152	305	∅ 10: 318 ∅ 12: 313 ∅ 14: 325	117		
M/F-3	120	235	218	420	437	148		

* Forestay tensioner in middle position

** Toggle eye screwed in completely

TL (top terminal length) must be measured.

Calculating the ofcut measurement			
C =	P	-	B
C =	_____	-	_____
C =	_____ mm		

See packing list for furling section length P

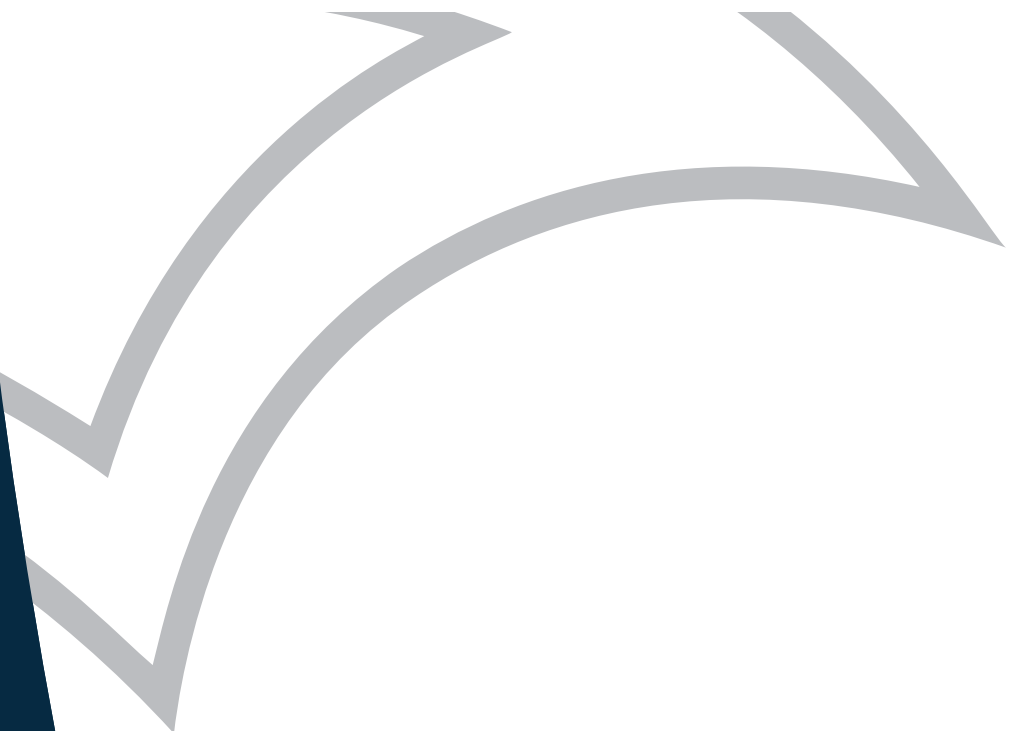

1	Packing list	3
2	About this manual.....	6
2.1	Introduction	6
2.2	Typographical conventions	6
2.3	Calculations	6
3	Safety	7
3.1	Intended use	7
3.2	Information for your safety	7
3.3	Hazards from improper use of the furling system.....	7
3.4	Installation and maintenance safety instructions.....	8
4	Design and function.....	9
4.1	Overview	9
4.2	Forestay tensioner	10
4.3	Function	10
5	Assembly	11
5.1	Adjusting the distance from drum to deck	11
5.2	Completing the forestay	12
5.2.1	Adjusting the furling section length.....	12
5.2.2	Preparing the top bushing	14
5.2.3	Preparing the rod forestay.....	15
5.2.4	Preparing the wire forestay	19
5.3	Fitting the furling sections	23
5.4	Fitting the bushing stopper (with rod forestay, no furling section reinforcement)	24
5.5	Fitting the furling section reinforcement (optional, with rod forestay)	25
5.6	Fitting the sail feeder and the halyard swivel	26
5.7	Sliding the furling section adapter onto the furling section	27
5.8	Connecting the rod forestay to the furling system	27
5.9	Connecting the wire forestay to the furling system.....	28
5.10	Fitting the furling section adapter to the furling section	29
5.11	Mounting the top bushing.....	30
5.12	Installing the system.....	30
5.12.1	Toggle on the masthead.....	30
5.12.2	Fixing the toggle to the chain plate.....	31
5.12.3	Minimum angle between forestay and halyard of 10°	32

5.13	Adjusting the forestay	33
5.14	Attaching the furling section adapter to the tack ring	36
5.15	Moving the halyard swivel into final position	37
5.16	Fitting the furling rope to the drum.....	37
5.17	Direction of rotation	38
5.18	Guiding the furling rope	39
5.19	Fitting the protective cage	40
6	Operation	41
6.1	Wire pennant	41
6.2	Furling and unfurling the sail	41
6.2.1	Furling.....	42
6.2.2	Unfurling the sail.....	42
6.2.3	Reefing	42
6.3	Use as a forestay furling section.....	43
7	Maintenance	44
7.1	Prior to each use	44
7.2	After each use	44
7.3	Annual maintenance.....	44
8	Disassembly	45
9	Storage.....	47
10	Disposal	48
11	Technical data	49
11.1	Dimensions.....	49
11.2	Furling section cross sections.....	50
12	Index.....	51









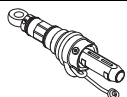

1 Packing list

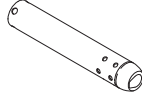



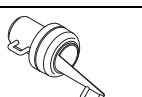
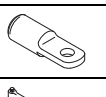

Date: _____

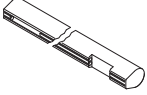
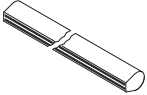
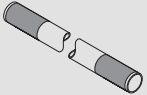
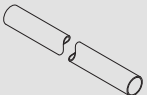

Order number: _____

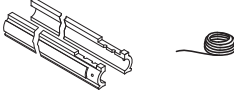
Dealer: _____

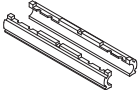
Customer: _____

Picture	Quantity	Name	Remarks
	_____	Drum bearing unit	Type MF - _____
	_____	Protective cage	
	_____	drum	
	_____	Section adapter	
	_____	Toggle	
	_____	Forestay adapter	
	_____	Swage terminal	
	_____	Rod nose	
	_____	Wire forestay	Length D = _____ mm
	_____	Rod forestay	Length D = _____ mm
	_____	Halyard swivel	Type: _____
	_____	Top terminal	
	_____	Shackle	Type: _____ Size: _____
	_____	Furling line	Size: _____ Type: _____

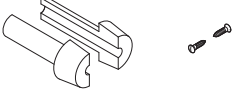
Picture	Quantity	Name	Remarks
Furling section type _____			
	_____	Feeder section	<input type="checkbox"/> 3000 mm
	_____	Standard furling section	<input type="checkbox"/> 1500 mm
	_____		<input type="checkbox"/> 3000 mm
	_____		<input type="checkbox"/> _____ mm
	_____		<input type="checkbox"/> _____ mm
	_____		<input type="checkbox"/> _____ mm
	_____		<input type="checkbox"/> _____ mm
	_____		<input type="checkbox"/> _____ mm
	_____	Top furling section	<input type="checkbox"/> _____ mm
			_____ mm
			Unshortened overall section length P = _____ mm
	_____	Spacer hose 500 mm	Marked red
	_____	Spacer hose 200 mm	
	_____	Spacer hose 340 mm	
	_____	Spacer hose 600 mm	
	_____	Spacer hose 1740 mm	
	_____	Top spacer	_____ mm
	_____	Standard bushing	
	_____	Furling section reinforcement	With rope
	_____	Bushing stopper	
	_____	Furling section connector	
	_____	Threaded plate for furling section connector	

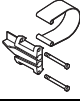
Picture	Quantity	Name	Remarks
	_____	Screw for furling section connector	
	_____	Top bushing	Split, with screws
	_____	Bottom threaded plate	With screws
	_____	Sail feeder with clip	With screws
	_____	Hex key set	
	_____	Operating instructions	
Optional equipment			

Compiled by: _____

On: _____
Signature

2 About this manual

2.1 Introduction

These instructions are directed at owners of furling systems as well as anyone involved in the assembly, use or maintenance of such systems.

Its use requires the appropriate sailing qualifications. Inexperienced individuals on board must be trained and supervised by the skipper.

Assembly and repair work may only be carried out by qualified specialists.

Read the instructions before using the furling system or carrying out any assembly, disassembly or maintenance work.

2.2 Typographical conventions

Warnings are specially indicated:

▲ Warning

'Warning' is used to indicate information which is likely to lead to serious injury or death if not followed.

▲ Caution

"Caution" is used to indicate information which is likely to lead to minor or moderate injury if not followed.

Notice

"Notice" indicates information warning of the possibility of material damage.

2.3 Calculations

Please see the dust jacket flaps for information pertaining to the calculations required for assembly.

3 Safety

3.1 Intended use

The MF is a manual furling system for fore sails.

The furling system is designed for reefing or furling a fore sail by rolling it up. It is operated using a furling rope on a drum. The sail can be rolled up completely (furled) or partially (reefed).

The furling system is equipped with a length adjuster for trimming of mast and sail. The length adjuster should be used at the mooring, not when sailing.

Use as a forestay furling section without reefing or furling function is also possible. The halyard swivel is lowered down to a position below the sail feeder. Disassemble the protective cage and drum.

No conversions or modifications of the furling system may be carried out.

Do not use the furling system.

- For attaching other objects as fore sails.
- As a winch.

3.2 Information for your safety

- Read these instructions before using or working on the furling system.
- Always keep the instructions close to the furling system.
- In addition to these instruction, the owner's manual and manuals for other on-board equipment must be observed.

3.3 Hazards from improper use of the furling system

Parts of the body, hair or clothing may get caught in the area of the drum and the sail attachment. Fingers may be crushed. The furling system may move in the wind.

The furling system and the furling rope pose a risk of stumbling.

Observe the following instructions:

- Its use requires the appropriate sailing qualifications. Inexperienced individuals on board must be trained and supervised by a trained individual. Do not leave children unattended on the furling system.
- Prior to each use check the furling system for damage. Do not use the furling system if it is damaged.
- When using the furling system make sure that no one is in the direct vicinity of the system.
- Always exercise prudence on board.

3.4 Installation and maintenance safety instructions

Improper installation and maintenance may result in serious injury including death.

- Assembly and repair work may only be carried out by qualified specialists at a location with suitable equipment. Use appropriate slings to lift the system.
- Carry out all maintenance tasks and inspection at the intervals specified in this manual.
- Only carry out the repairs maintenance tasks described in these instructions. For any other repairs please consult a service station.

4 Design and function

4.1 Overview

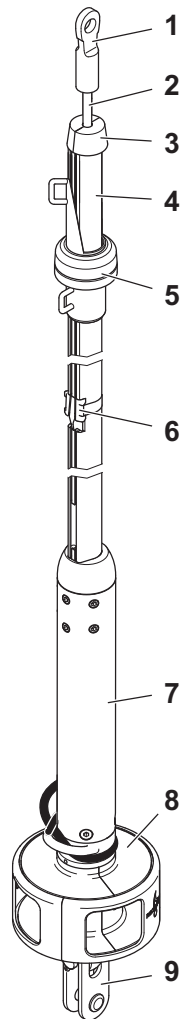

- 1 Top terminal
- 2 Forestay
- 3 Top bushing
- 4 Furling section
- 5 Halyard swivel

- 6 Sail feeder
- 7 Furling section adapter
- 8 Drum with protective cage
- 9 Toggle

4.2 Forestay tensioner

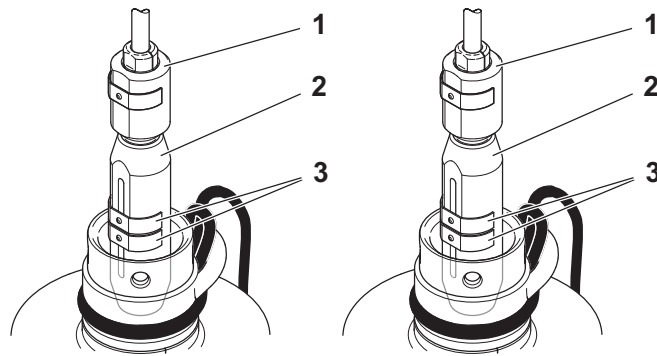

- 1 Forestay adapter
- 2 Adjuster tube
- 3 Securing clip

4.3 Function

The furling system reefs the fore sail by winding it around a foil that rotates around the forestay. A groove in the foil holds the sail luff.

The sail is manually is furled in by using a furling rope around a drum.

5 Assembly

5.1 Adjusting the distance from drum to deck

In order for the drum to have the planned distance from deck later on, the distance of the drum's toggle eye must be adjusted. Also see "11.1 Dimensions".

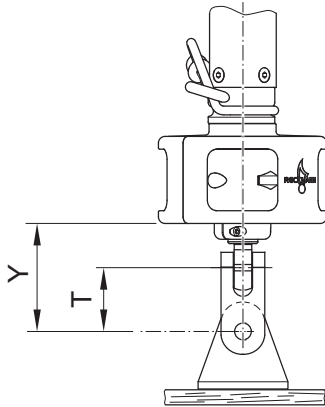

⚠ Warning

The furling system may tear apart if not properly secured.

If the furling system tears apart this may cause serious injury including death.

- Unscrew the toggle eye only as far as the thread is still completely screwed in.
- There should be no space between the contact surfaces of the safety caps following assembly. After tightly securing the safety caps, check whether they are positioned flush on the toggle eye.

1. Unscrew the two Allen screws on the safety caps.
2. Remove safety caps.

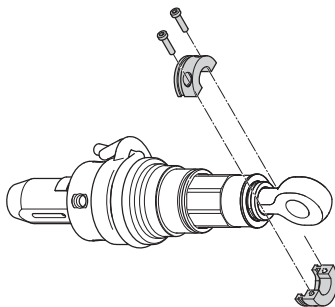

3. Unscrew or screw in the toggle eye to adjust the height of the drum to the desired setting. The thread must remain completely screwed in.
4. Turn the toggle eye so the flat surfaces of the toggle eye rod are parallel to the flattened surfaces in the groove for the safety caps.

5. Put on the safety caps. If they do not fit properly:
 - Turn the toggle eye back and forth until the safety caps are properly seated.
 - Check whether the thread is completely screwed in. Even though it is only slightly protruding from the bore hole, the safety cap cannot be properly fitted.
6. Firmly attach the safety caps using two Allen screws.

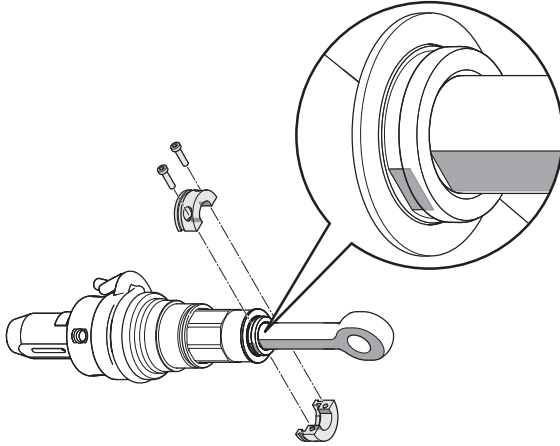

5.2 Completing the forestay

5.2.1 Adjusting the furling section length

If a top furling section and a top spacer are not specified on the list at the beginning of this manual, a furling section and a corresponding spacer hose must be shortened by the offcut measurement 'C'.

For the offcut measurement 'C' please see the calculations on the flap.

5.2.1.1 Shortening the top furling section

Notice

Risk of material damage through shortening of an improper furling section

Shortening of an improper furling section can make the furling section unsuitable for later assembly.

- Only shorten standard furling sections of length 3000 mm.
- Do not shorten the feeder section or a short furling section.

Shorten one of the 3000-mm-long standard furling sections by the calculated amount 'C' using a handsaw.

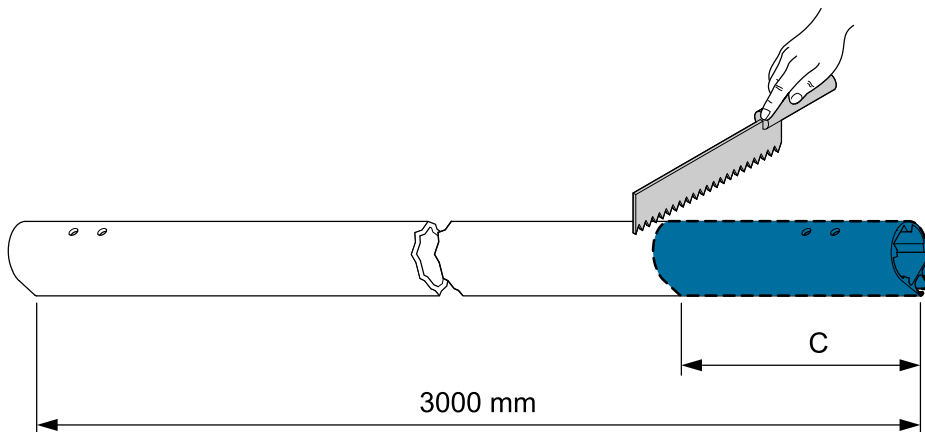

The shortened furling section will become the top furling section during assembly.

5.2.1.2 Shortening the top spacer

Shorten the 1740-mm-long spacer hose by the amount 'C' using a sharp knife.

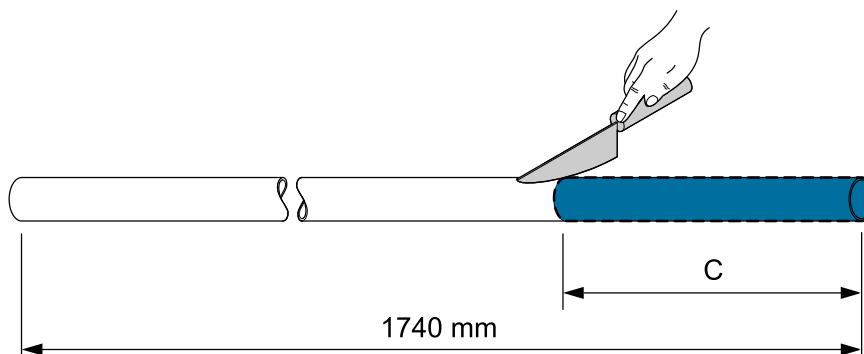

The shortened spacer hose will become the top spacer during assembly.

5.2.2 Preparing the top bushing

After assembly the top bushing will cover the top furling section.

The following can be used as a top furling section:

- A standard furling section that has been shortened to a length less than 3000 mm but greater than 1500 mm,
 - If furling section shortening is not necessary, a standard furling section 3000 mm long.
1. Insert the two halves of the top bushing into the top furling section in such a way that the join line formed by their mating surfaces is lined up with the groove in the furling section.

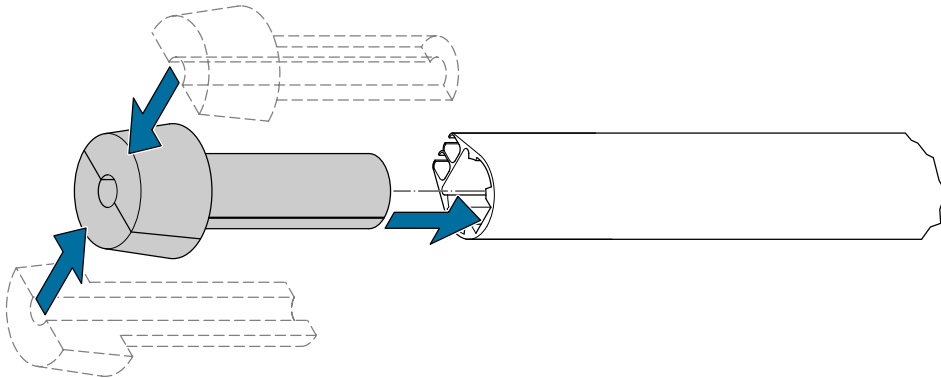

2. Drill through the furling section and the top bushing half on each side of the furling section using a drilling bit.

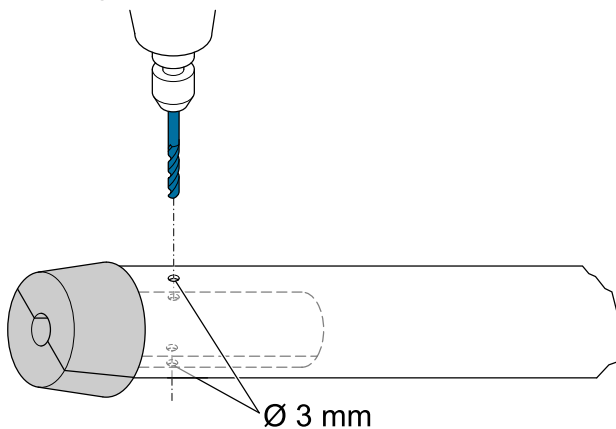

3. Take the top bushing halves out of the furling section and set them aside for later assembly.

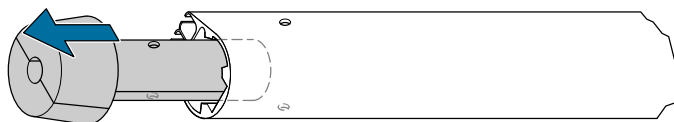

5.2.3 Preparing the rod forestay

5.2.3.1 Assembling the top terminal on the rod forestay

Assemble the top terminal according to the manufacturer's instructions.

First cold-head one end of the rod forestay. Once both ends of the rod forestay have been cold-headed, bushings or spacer hoses can no longer be fitted.

5.2.3.2 Sliding bushings and spacer hoses on to the rod forestay

Errors made in sliding on of bushings and spacer hoses can make assembly of the furling sections impossible. Take particular care when sliding on the bushings and spacer hoses. Follow the given sequence precisely.

For the procedure to be taken for a wire forestay see "5.2.4 Preparing the wire forestay " starting on page **19**

5.2.3.2.1 Overview

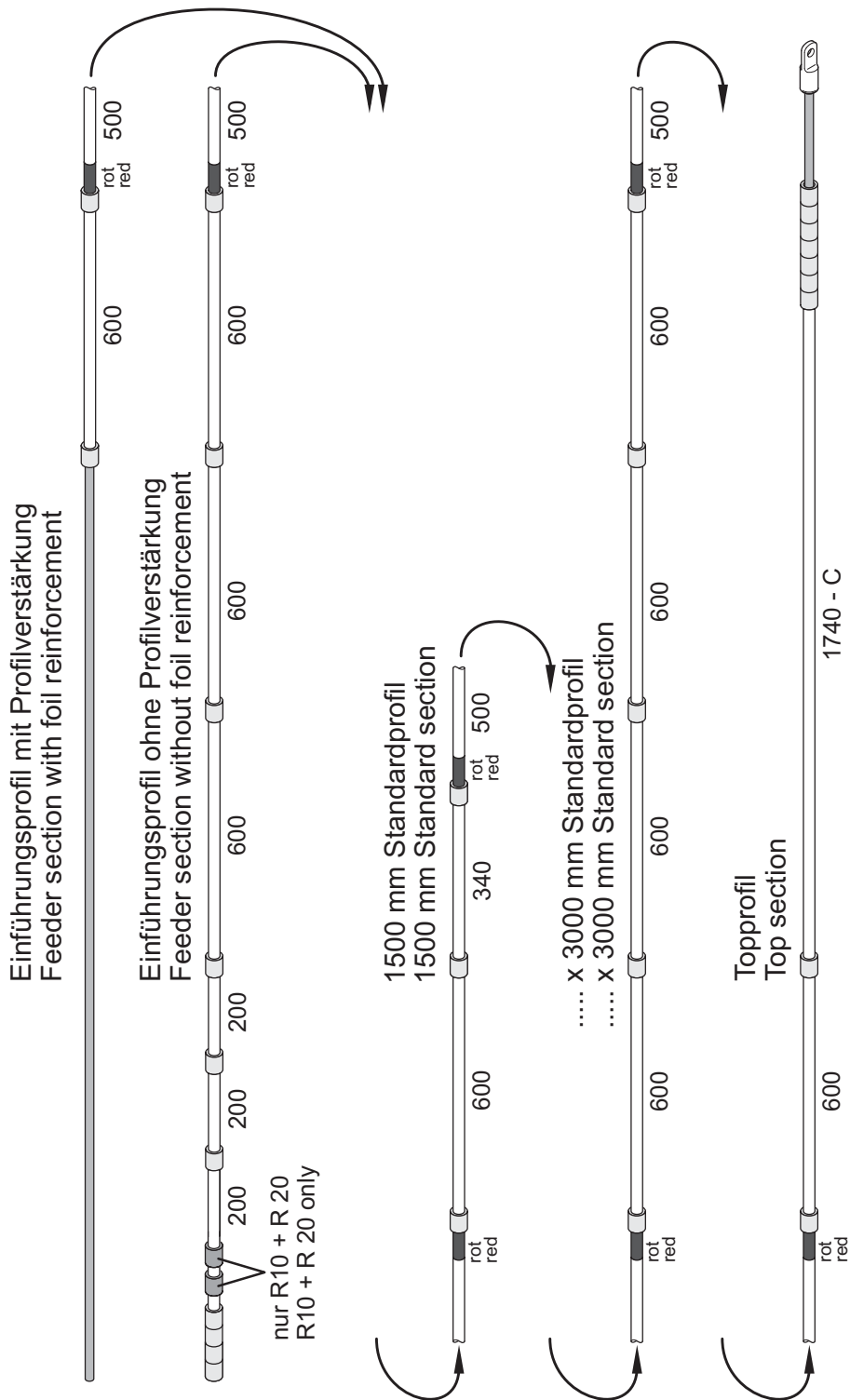

Slide bushings and spacer hoses on to the rod forestay from below.

5.2.3.2.2 Sliding bushings and spacer hoses on for the top furling section

1. Slide on seven standard bushings.
2. Slide on the top spacer. The top spacer is between 240 mm and 1740 mm long.
3. Slide on a standard bushing.
4. Slide on a 600-mm long spacer hose.
5. Slide on a standard bushing.
6. Slide on a 500-mm long spacer hose with ends marked red.

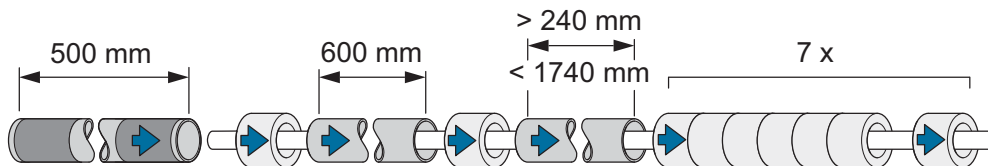

The furling section connectors will later be located on the spacer hoses marked red.

5.2.3.2.3 Sliding on bushings and spacer hoses for 3000-mm long standard furling sections

Carry out the following steps for each of the 3000-mm long standard furling sections. The feeder section is not included.

1. Slide on a standard bushing and a 600-mm long spacer hose and repeat three more times.
2. Slide on a standard bushing.
3. Slide on a 500-mm long spacer hose with ends marked red.

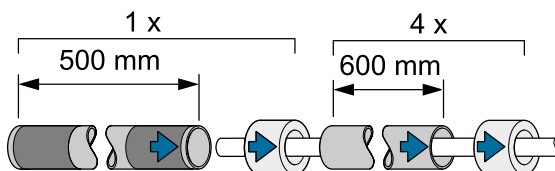

5.2.3.2.4 Sliding on bushings and spacer hoses for a 1500-mm long standard furling section

The following steps are only necessary if a 1500-mm long furling section is present. If no 1500-mm long furling section is present, continue with "5.2.3.2.5 Sliding on bushings and spacer hoses for the feeder section".

1. Slide on a standard bushing.
2. Slide on a 340-mm long spacer hose.
3. Slide on a standard bushing.
4. Slide on a 600-mm long spacer hose.
5. Slide on a standard bushing.

- Slide on a 500-mm long spacer hose with ends marked red.

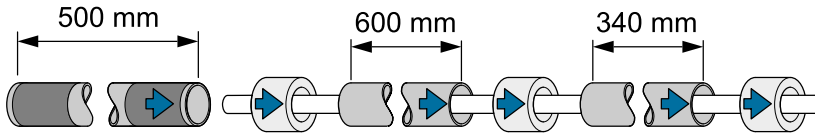

5.2.3.2.5 Sliding on bushings and spacer hoses for the feeder section

- Slide on a standard bushing, a 600-mm long spacer hose and another standard bushing.

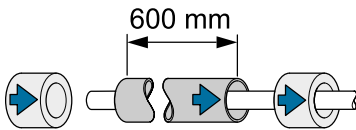

If a furling section reinforcement should be fitted, do **not** carry out the following steps.

- Slide on a 600-mm long spacer hose and a standard bushing and repeat one more time.
- Slide on a 200-mm long spacer hose and a standard bushing and repeat two more times.
- Slide on three more standard bushings.

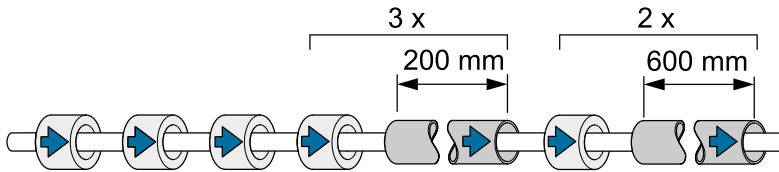

- Only R10 and R20:** Slide on two additional standard bushings.

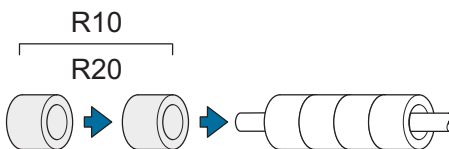

5.2.3.3 Cold-heading the rod head

Notice

After the rod head has been cold-headed no more bushings or spacer hoses can be fitted and their order can no longer be changed.

Only cold-head the lower rod head after ensuring that all bushings and spacer hoses have been properly installed.

Cold-head the rod head according to the rod manufacturer's instructions.

Once the rod head has been cold-headed, continue the assembly with 5.3 Fitting the furling sections .

5.2.4 Preparing the wire forestay

5.2.4.1 Roller-swaging the lower terminal on to the wire forestay

▲Warning

Risk of breaking the forestay

The terminal must be fitted by qualified personnel using suitable tools.

Roller-swage the supplied lower terminal on to the wire forestay.

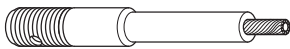

5.2.4.2 Sliding bushings and spacer hoses on to the wire forestay

Errors made in sliding on of bushings and spacer hoses can make assembly of the furling sections impossible. Take particular care when sliding on the bushings and spacer hoses. Follow the given sequence precisely.

For the procedure to use for a rod forestay see "5.2.3 Preparing the rod forestay" starting on page 15.

5.2.4.2.1 Overview

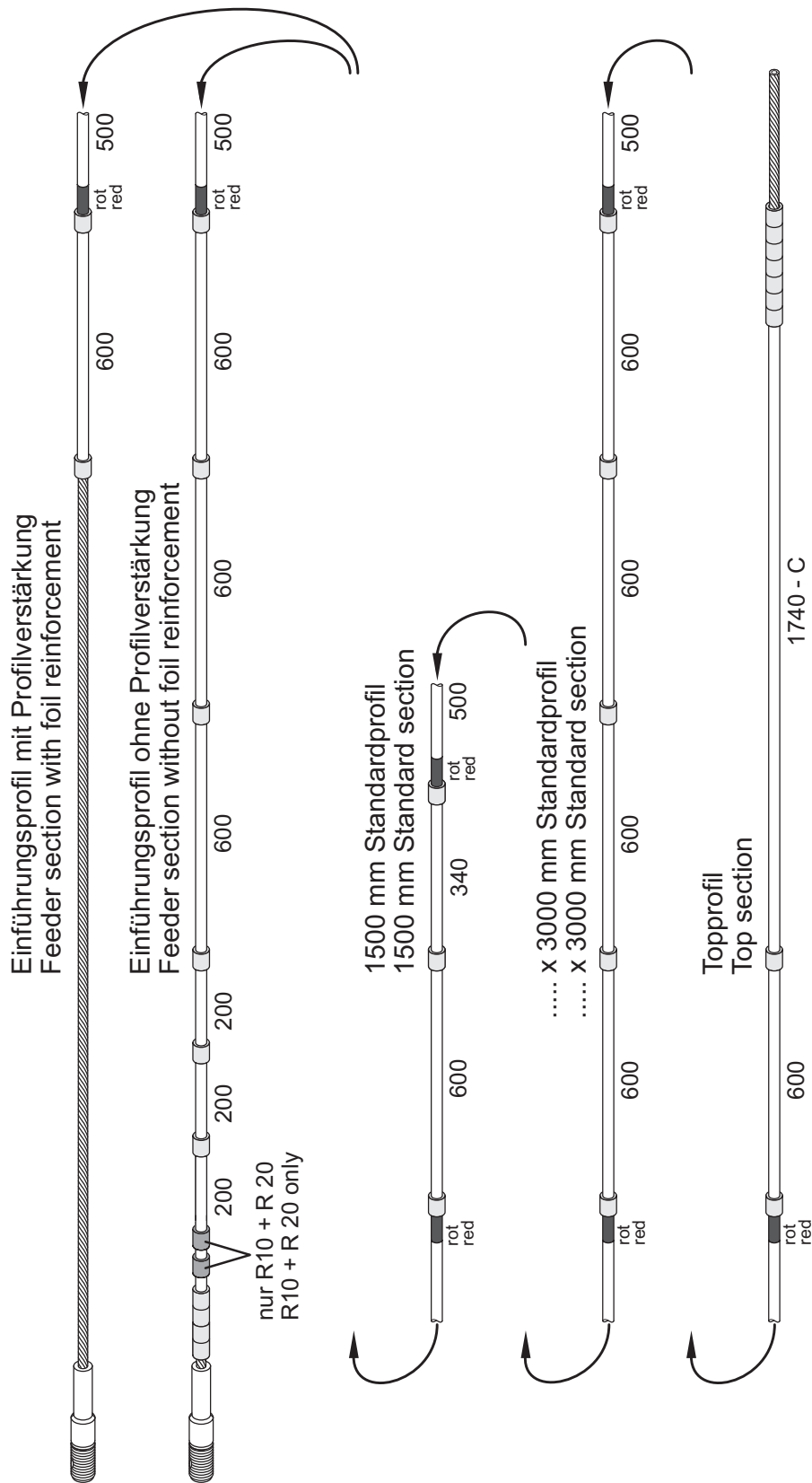

Slide bushings and spacer hoses on to the wire forestay from above.

5.2.4.2.2 Sliding on bushings and spacer hoses for the feeder section

If a furling section reinforcement is being fitted to the feeder section, skip the first vier steps. In this case begin with step 5.

1. **Only R10 and R20:** Slide on two standard bushings.

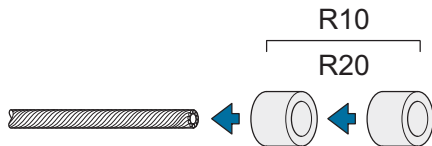

2. Slide on three standard bushings.
3. Slide on a standard bushing and a 200-mm long spacer hose and repeat two more times.
4. Slide on a standard bushing and a 600-mm long spacer hose and repeat one more time.

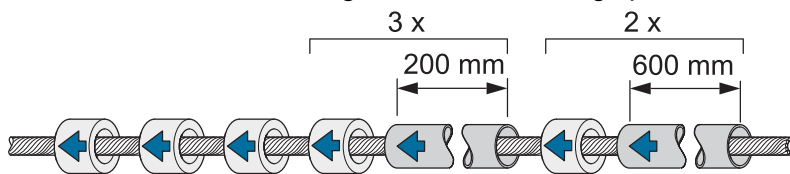

5. Slide on a standard bushing, a 600-mm long spacer hose and another standard bushing.
6. Slide on a 500-mm long spacer hose with ends marked red.

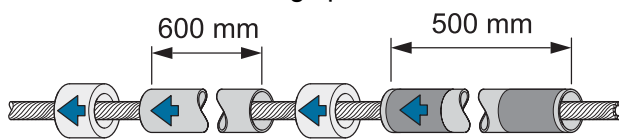

The furling section connectors will later be located on the spacer hoses marked red.

5.2.4.2.3 Sliding bushings and spacer hoses on for a 1500-mm long furling section

The following steps are only necessary if a 1500-mm long furling section is present. If no 1500-mm long furling section is present, continue with "5.2.4.2.4 Sliding on bushings and spacer hoses for 3000-mm long standard furling sections".

1. Slide on a standard bushing.
2. Slide on a 600-mm long spacer hose.
3. Slide on a standard bushing.
4. Slide on a 340-mm long spacer hose.
5. Slide on a standard bushing.
6. Slide on a 500-mm long spacer hose with ends marked red.

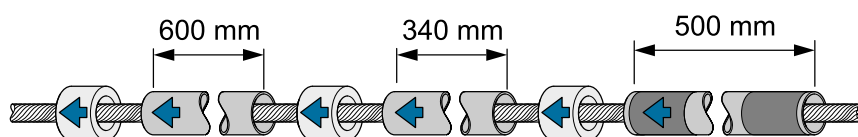

5.2.4.2.4 Sliding on bushings and spacer hoses for 3000-mm long standard furling sections

Carry out the following steps for each of the 3000-mm long standard furling sections. The top furling section should not be included.

1. Slide on a standard bushing and a 600-mm long spacer hose and repeat three more times.

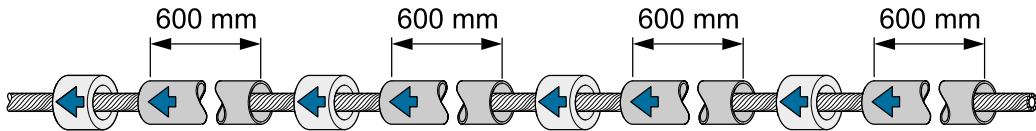

2. Slide on a standard bushing.
3. Slide on a 500-mm long spacer hose with ends marked red.

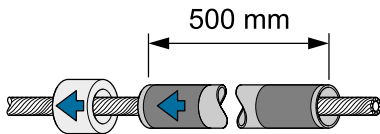

5.2.4.2.5 Sliding on bushings and spacer hoses for the top furling section

1. Slide on a standard bushing.
2. Slide on a 600-mm long spacer hose.
3. Slide on a standard bushing.
4. Slide on the top spacer.
5. Slide on seven standard bushings.

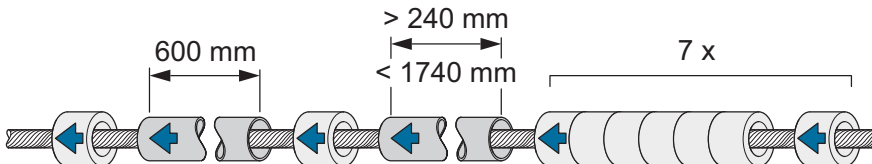

5.2.4.3 Assembling the top terminal on the wire forestay

⚠Warning

Risk of breaking the forestay

- The top terminal must be fitted by qualified personnel using suitable tools.

Notice

Once the terminal has been installed on the wire forestay, bushings or spacer hoses can no longer be fitted.
Only install the terminal after ensuring that all bushings and spacer hoses have been properly installed.

- Roller-swage the terminal on to the wire forestay
- or:
- Install a swageless stud terminal according to the supplied assembly instructions.

5.3 Fitting the furling sections

Start fitting the furling sections with the top furling section. The top furling section is the furling section with the holes drilled into it for the top cap.

1. Slide the top furling section from below up to the terminal on the forestay. The end with the drill holes for the top cap must be pointing towards the terminal.



2. Lay the two halves of a furling section connector around the spacer hose marked red.

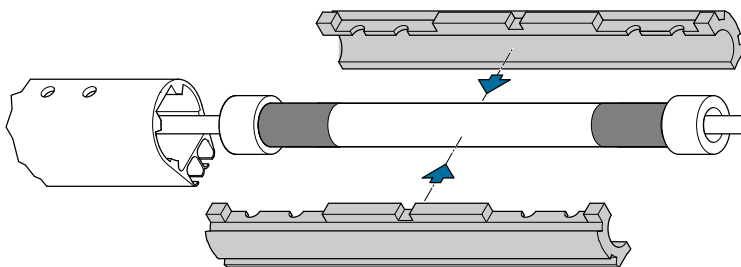

3. Place the threaded plate in the recess in the furling section connector.
4. Slide the furling section connector with threaded plate halfway into the furling section.

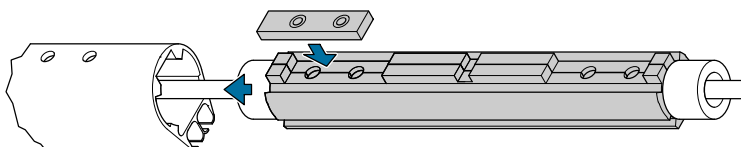

5. Secure the furling section to the furling section connector with two self-locking screws. Do not tighten the screws completely yet.

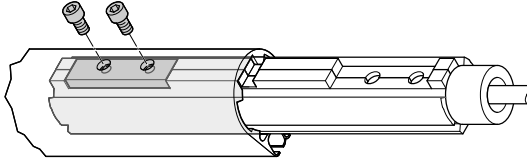

6. Place the threaded plate in the second recess in the furling section connector.

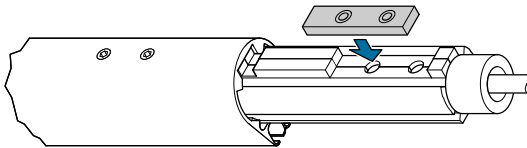

7. Slide a standard furling section on to the furling section connector.

8. Secure the standard furling section with two self-locking screws.

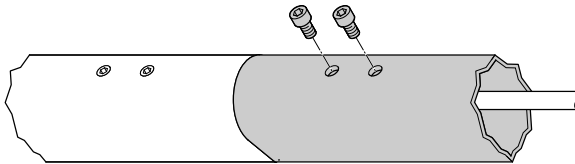

9. When all four screw threads are engaged in the tapped holes in the threaded plate, tighten the screws.

10. Repeat steps 2 to 9 with other furling sections in the following order:

- 3000-mm long standard furling sections
- 1500-mm long standard furling section (if present).

11. Repeat steps 2 to 5 for the feeder section. If no furling section reinforcement is being fitted later on, also repeat steps 6 to 9 with the feeder section.

5.4 Fitting the bushing stopper (with rod forestay, no furling section reinforcement)

1. Place the two halves of the bushing stopper on the forestay.
2. Place the threaded plate in the recess of the bushing stopper.

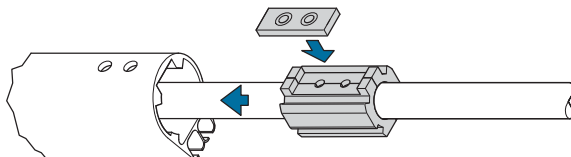

3. Carefully slide the bushing stopper into the feeder section until the threaded holes on the threaded plate are below the matching holes on the feeder section.

- Secure the threaded plate with 2 self-locking screws in the feeder section.

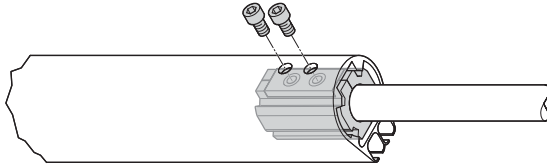

5.5 Fitting the furling section reinforcement (optional, with rod forestay)

- All furling sections except for the feeder section must be fitted.
 - Only the following elements may be fitted on the forestay below the last furling section connector: standard bushing – 600-mm hose – standard bushing.
- Place the halves of the furling section reinforcement on the forestay in places where there are no bushings or spacer hoses. The ends with the drill holes must point to the lower end of the forestay.
 - Thread one end of the supplied rope through the holes in the furling section reinforcement and tie a knot in it.

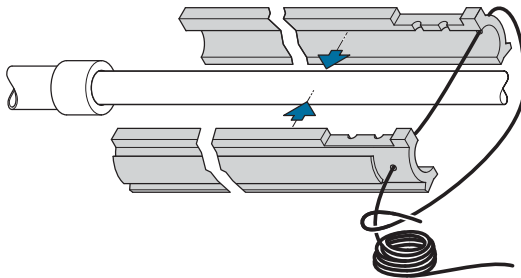

- Insert the other end of the rope through the feeder section.
- Place the threaded plate in the recess of the furling section reinforcement.
- Slide the feeder section over the furling section reinforcement. Pull the furling section reinforcement through the feeder section with the rope until the furling section reinforcement reaches the lower edge of the feeder section.

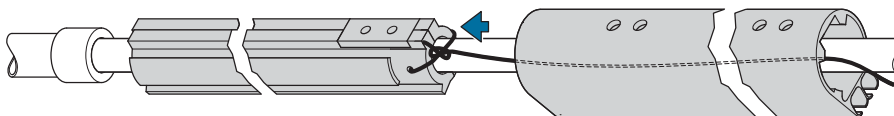

- Place the threaded plate in the recess in the furling section connector.
- Slide the feeder section on to the furling section connector. Continue keeping the furling section reinforcement at the lower end of the forestay with the rope.
- Secure the feeder section with two self-locking screws. When all four screw threads are engaged in the tapped holes in the threaded plate, tighten the screws.
- Secure the threaded plate to the furling section reinforcement with 2 self-locking screws.

10. Cut the rope off the furling section reinforcement.

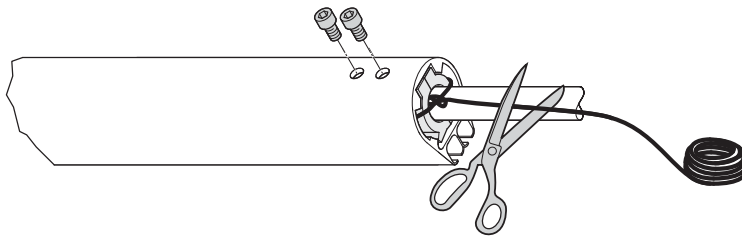

5.6 Fitting the sail feeder and the halyard swivel

The halyard swivel is initially attached below the sail feeder. This enables the furling section package on the halyard swivel to be pulled up.

1. Place the sail feeder in the recess.
2. Snap the retaining clip for the sail feeder around the feeder section.
3. Secure the sail feeder and the retaining clip with two screws.

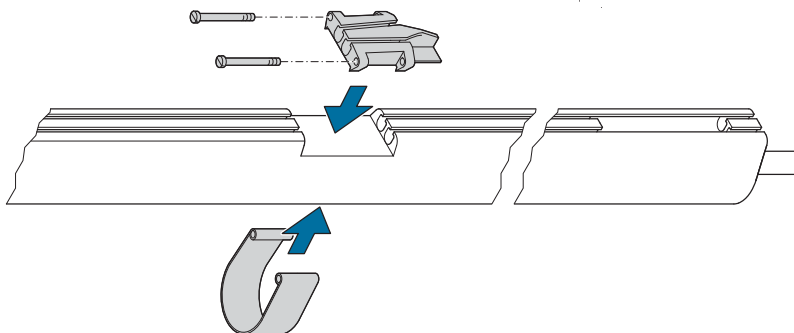

4. Slide the halyard swivel over the feeder section until it is above the sail feeder.

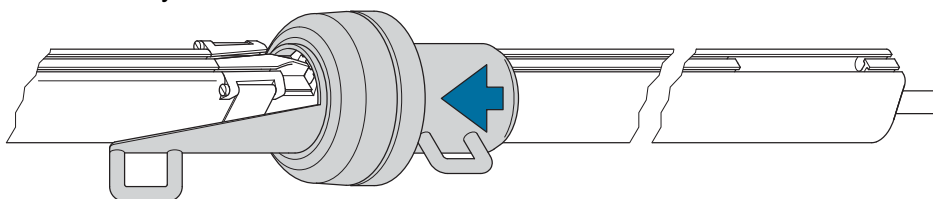

5.7 Sliding the furling section adapter onto the furling section

Slide the furling section adapter over the feeder section up to the halyard swivel.

Don't screw the furling section adapter to the section yet.

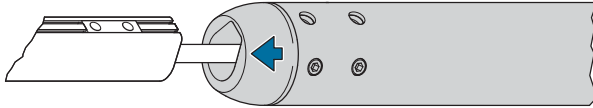

5.8 Connecting the rod forestay to the furling system

⚠ Warning

The furling system may loosen itself if the securing clips are fitted improperly.

If the furling system unscrews and becomes loose this may cause serious injury including death.

- Only use a securing clip with a shorter pin to secure the rod nose or the swage terminal in the forestay adapter.
- Only use the securing clips with longer pins to secure the adjuster tube.
- Following installation of the securing clips, check whether all three securing clips are properly seated.

1. Remove both securing clips from the forestay adapter.
2. Unscrew the forestay adapter from the adjuster tube.

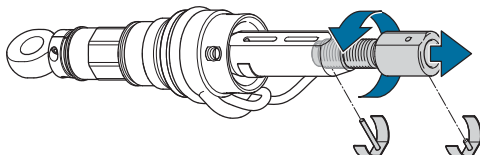

3. Place the halves of the forestay on the rod nose.
4. Screw the forestay adapter onto the rod nose until the holes on the forestay adapter and the red nose overlap.
5. Place a securing clip with shorter pin onto the forestay adapter in order to secure the rod nose in the forestay adapter.

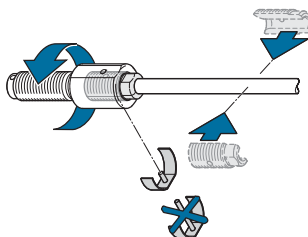

6. Screw the forestay adapter back into the adjuster tube until the hole at the lower end of the forestay adapter is visible in the recess of the adjuster tube.
7. Secure the forestay adapter in the adjuster tube using a securing clip with longer pin.

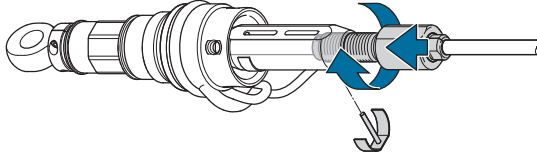

5.9 Connecting the wire forestay to the furling system

⚠ Warning

The furling system may loosen itself if the securing clips are fitted improperly.

If the furling system unscrews and becomes loose this may cause serious injury including death.

- Only use a securing clip with a shorter pin to secure the rod nose or the swage terminal in the forestay adapter.
- Only use the securing clips with longer pins to secure the adjuster tube.
- Following installation of the securing clips, check whether all three securing clips are properly seated.

1. Remove all three securing clips from the adjuster tube and the forestay adapter.
2. Unscrew the forestay adapter from the adjuster tube.

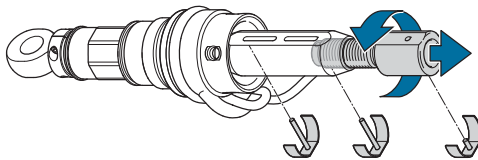

3. Screw the forestay adapter onto the swage terminal until the holes on the forestay adapter and the swage terminal overlap.
4. Place the securing clip with the shorter pin onto the forestay adapter to secure the swage terminal in the forestay adapter.

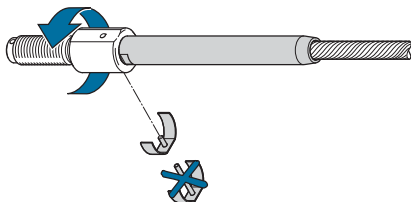

5. Unscrew the adjuster tube clockwise from the drum axle. The adjuster tube has a left-hand thread on this side. Then screw on the adjuster tube in anti-clockwise direction again two thread lengths (= two turns).

6. Insert the forestay adapter as far into the adjuster tube that the thread is nestled in it. Turn the adjuster tube as shown in order to screw in the forestay adapter and the drum axle simultaneously. Screw in until the holes on the lower end of the forestay adapter and on the drum axle are visible in the recess of the adjuster tube.
7. Secure the adjuster tube using two securing clips with longer pins.

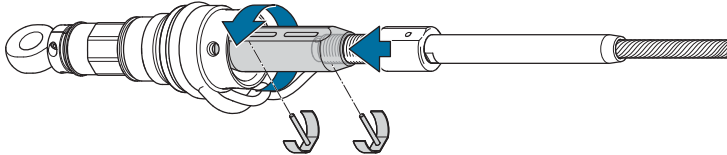

5.10 Fitting the furling section adapter to the furling section

Prerequisite

- The groove of the furling section is facing upwards.

Procedure

1. Place a square retainer in the recess of the feeder section.
2. Slide the furling section adapter over the square retainer so that the holes in the furling section adapter cover the holes in the square retainer.
3. Screw furling profile adapter to square retainer.

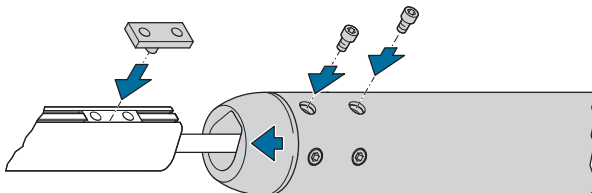

Don't fix the furling section adapter to the furling system yet.

5.11 Mounting the top bushing

Insert the two halves of the top bushing into the top furling section and screw in.

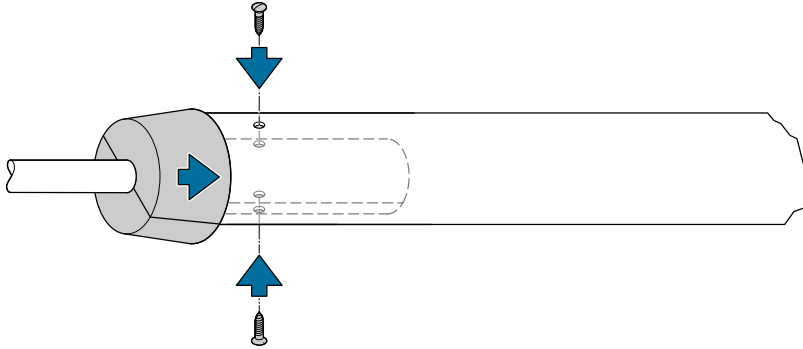

5.12 Installing the system

5.12.1 Toggle on the masthead

⚠ Warning

Risk of forestay breakage

The forestay is subjected to high bending moments when there is no mast toggle mounted. If the forestay breaks, severe injuries may be incurred.

- Connect the forestay to the mast with a toggle.

5.12.2 Fixing the toggle to the chain plate

⚠ Warning

The furling system may tear apart if improperly secured.

If the furling system tears apart this may cause serious injury including death.

- Secure the toggle bolts using splint pins. Bend the splint pins well apart.
- Do not reuse splint pins.

⚠ Warning

Shear and crushing hazard on bolt holes

Fingers may be sheared off in the bolt holes.

- Never stick your finger into a bolt hole.

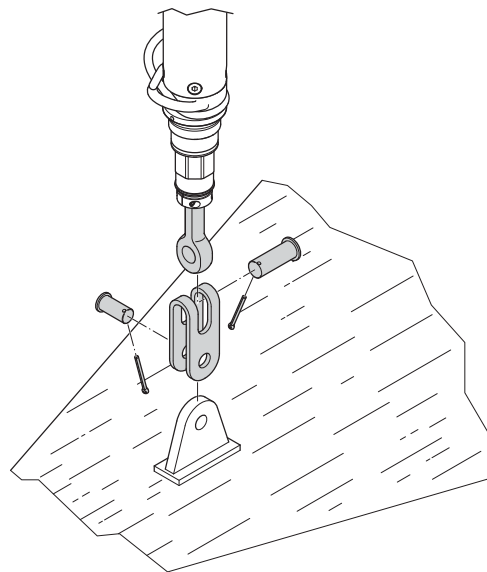

5.12.3 Minimum angle between forestay and halyard of 10°

When the sail is hoisted the halyard must run at an angle of at least 10° from the halyard swivel to the forestay. Otherwise the halyard can wrap around the furling section and cause the furling system to jam.

Install a halyard lead on the mast if the angle is less than 10°.

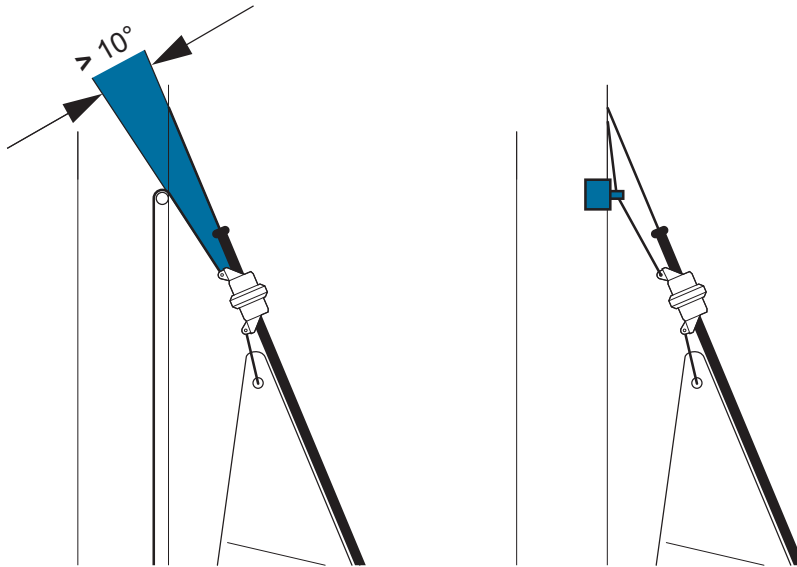

5.13 Adjusting the forestay

▲ Warning

The furling system may become unscrewed by adjusting the forestay tension or improper attachment of the securing clips.

If the furling system unscrews and becomes loose this may cause serious injury including death.

- Pay particular care when adjusting the forestay tension. Make sure that the adjust tube turns in the right direction.
- Do not further extend the forestay tension if the holes for the securing clips have reached the outer edges of the recesses in the adjuster tube. Turning the adjuster tube clockwise extends the forestay tension.
- Following adjustments, insert the securing clips and check for proper seating.

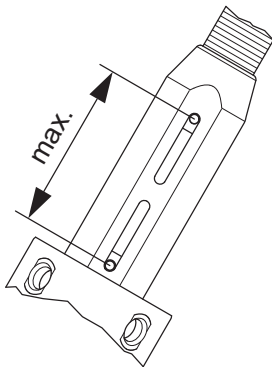

▲ Warning

Hazard from non-secured furling section package

A furling section package or furling section adapter may fall and crush hands.

- Secure the furling section package in such a way that it cannot slide down onto the forestay.
- Secure the furling section adapter to the furling section to prevent it from sliding down.

The length of the forestay can be adjusted by turning the adjuster tube on the forestay tension. Turning anti-clockwise shortens the forestay, turning it clockwise lengthens it.

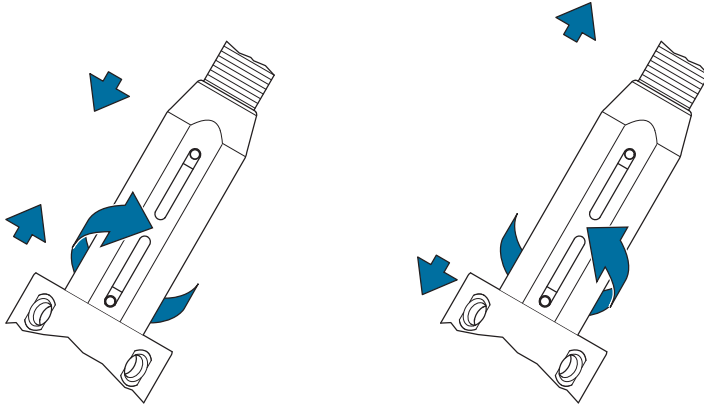

1. Turn the furling section so that the groove is facing forwards.
2. Pull the furling section package with a latch on the halyard swivel upwards until the top bushing of the top terminal is reached.
3. Remove the furling section adapter from the furling section. Slide the furling section adapter upwards and secure with adhesive tape. Remove the square retainer from the furling section.

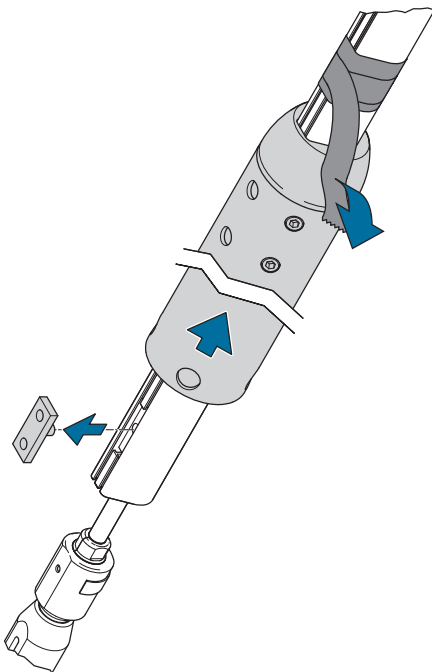

4. Remove both securing clips from the adjuster tube.

5. Hold the forestay adapter using a spanner. At the same time, use a second spanner to turn the adjuster tube in order to lengthen or shorten the forestay.

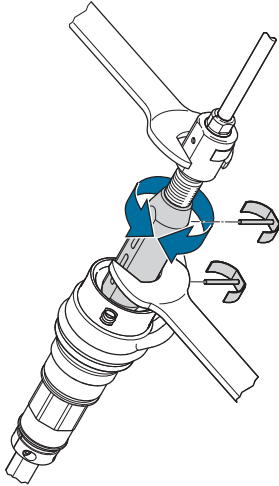

6. Replace both securing clips. Check whether the pins are properly seated in the corresponding holes on the forestay adapter and the drum axle.
7. Slide down the forestay adapter. Make sure that the groove is facing forwards. Place the square retainer back into the recess of the furling section. Screw the forestay adapter to the square retainer.

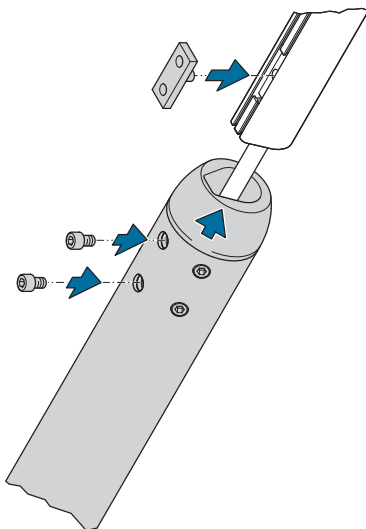

8. Carefully lower the furling section package.

5.14 Attaching the furling section adapter to the tack ring

1. Turn the outer part of the drum bearing unit so that the loop shackle is facing forwards.
2. Turn the furling section adapter with the furling section until
 - The furling section groove and the loop shackle are positioned flush.
 - The holes in the furling section adapter overlap the holes in the tack ring.
3. Secure furling section using for screws.

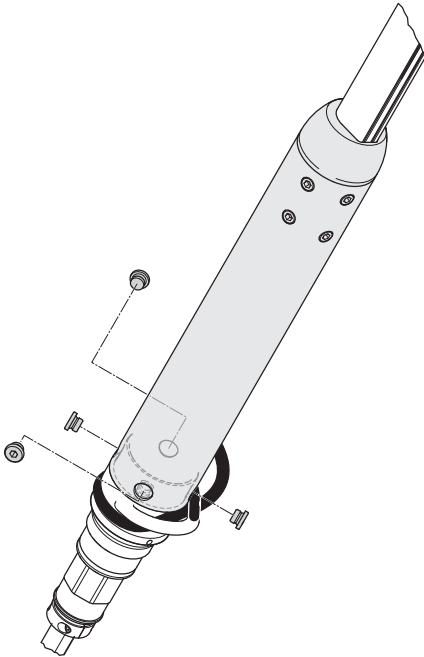

5.15 Moving the halyard swivel into final position

1. Remove the two screws on the sail feeder.
2. Remove retaining clip and sail feeder from the furling section.
3. Slide the halyard swivel up over the recess for the sail feeder.
4. Reattach the sail feeder using the retaining clip and two screws.

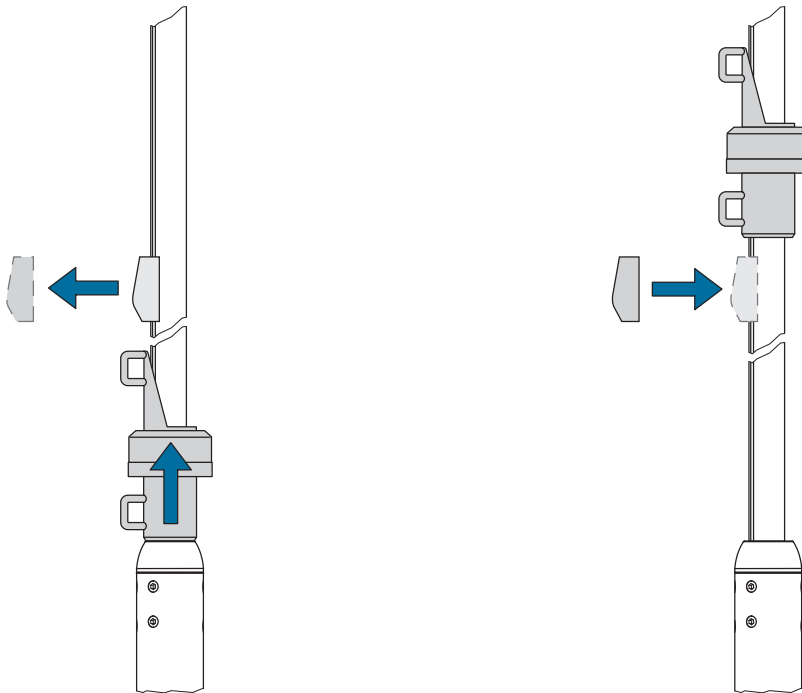

5.16 Fitting the furling rope to the drum

1. Insert the thinner end of the furling rope through the hole in a drum half and make a knot. Keep the knot as small as possible. It must have enough space in the groove of the drum.

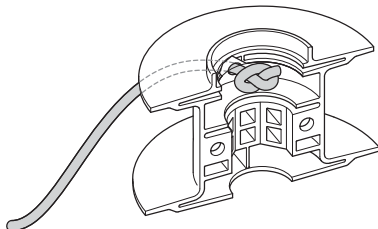

2. Install the drum with the collar facing upwards. Make sure that the stay below the furling rope catches in the corresponding groove.

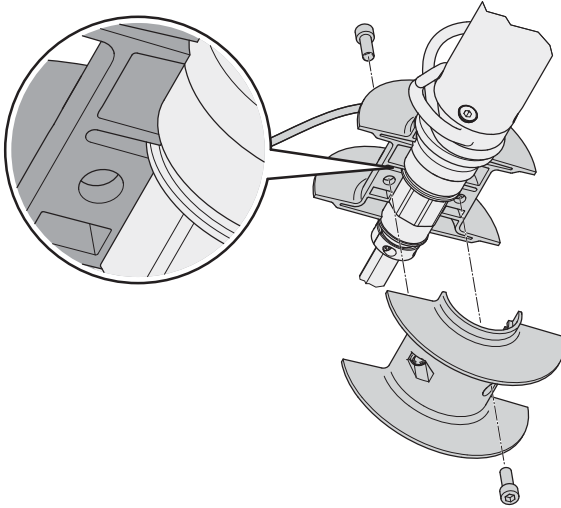

3. Screw drum halves together again. There may be no gap between the drum halves.

5.17 Direction of rotation

In principle, the furling system can roll up the sail clockwise or anticlockwise.

Select the direction of rotation to ensure that the side with the UV-resistant coating is facing outwards after the sail has been rolled up.

5.18 Guiding the furling rope

The furling rope must run as closely as possible to 90° to the forestay from the drum to the first guide block.

The furling rope can be guided from behind both port and starboard. We recommend guiding the furling rope over a point on the stern of the ship and allowing it to wind up the winch from behind.

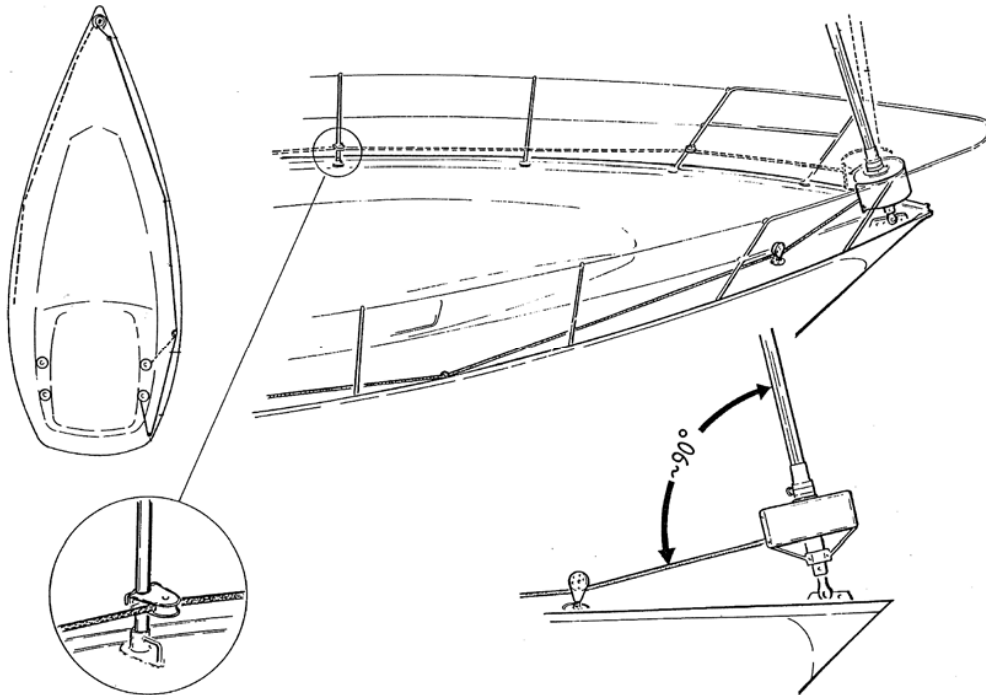

Approximately three turns should remain on the drum when the sail is completely unfurled.

5.19 Fitting the protective cage

Fit the protective cage so that the furling rope winds or unwinds from the centre of an opening. The furling rope may not rub against the edge of the protective cage. If the furling rope touches the protective cage this results in

- Chaffing of the furling rope.
- Deformation of the protective cage.
- Greater force required when reefing or furling.

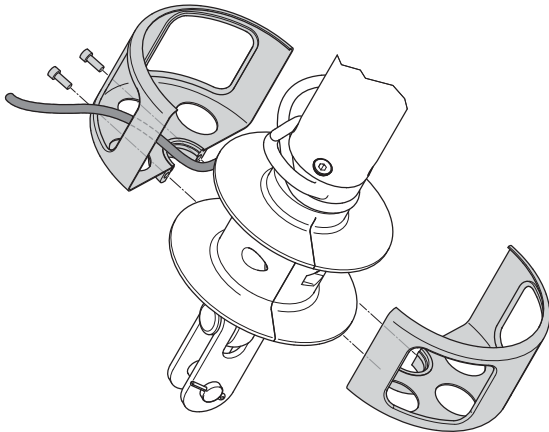

6 Operation

6.1 Wire pennant

When the sail is hoisted the halyard shackle must be as close as possible to the top end of the foil.

For a sail with a shorter luff a wire pennant must be fitted between the halyard swivel and the headsail.

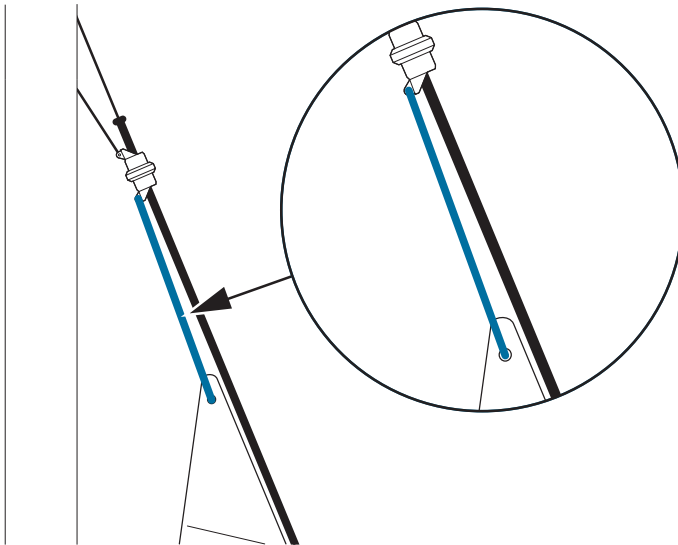

6.2 Furling and unfurling the sail

⚠ Warning

Risk of injury

- Prior to furling, make sure no one is in the area around the furling system.
- The operator must have an adequate view of the furling system and the sail. If this is not possible, a second person with an adequate view must maintain visual contact with the operator.
- Immediately stop the furling system if the sheet jams or the halyard starts wrapping.

Notice

Risk of damage to furling system

Jamming of the furling system will damage it.

- Only reef or unfurl the sail with an eased sheet.
- If the furling system becomes difficult to move, do not attempt to furl the sail with a great deal of force.
- Never furl counter to strong sheet tension.
- The halyard must be slightly tensioned.

6.2.1 Furling

In very light winds keep the sheet slightly tensioned so that the sail will furl tightly. In strong winds ease the sheet stepwise and reef the sail.

Stop reefing when the sheet has been rolled once or twice around the sail.

If the furling system becomes difficult to move, check the following:

- Is the halyard working correctly?
- Is the furling rope cleaning guided over blocks and deflection rollers?
- Is the sheet loose?
- Are any obstructions present?

6.2.2 Unfurling the sail

Slightly pull the furling rope when unfurling the sail.

Keep the furling rope under slight tension when the sail is completely unfurled. The remaining winds on the drum may otherwise become loose.

6.2.3 Reefing

A sheet lead positioned further in front is required when sailing with a reefed sail. For reefing proceed as follows:

1. Furl in the sail completely.
2. Adjust the new sheet lead position.
3. Unfurl the sail until the desired sail size is reached.
4. Secure the furling rope.

6.3 Use as a forestay furling section

For regatta use the furling system can be used as a forestay furling section without a roller furling function. This enables two sails to be swapped between each other using two halyards and setting sail on deck.

To carry out preparations proceed as follows:

1. Detach the protective cage from the drum.
2. Remove the sail feeder.
3. Let the halyard swivel lower all the way down.
4. Install the sail feeder again.

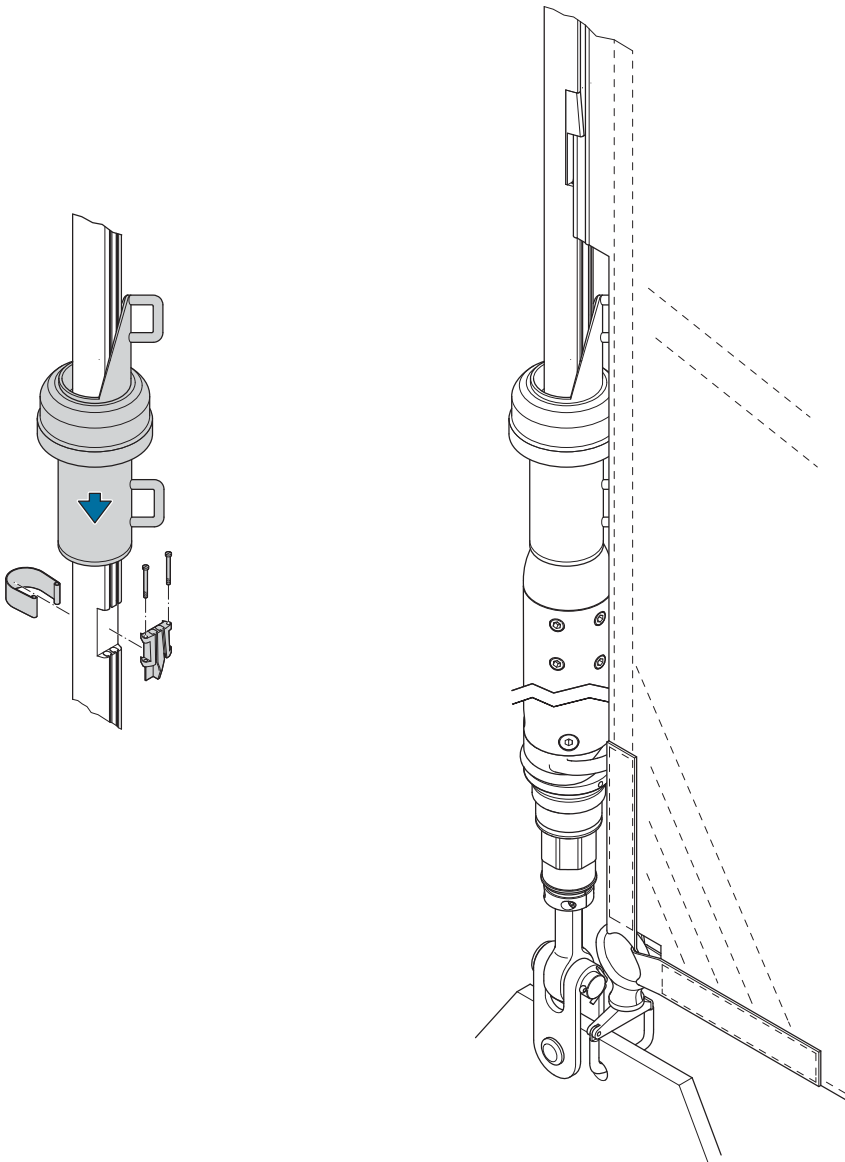

7 Maintenance

7.1 Prior to each use

- Check ropes and lashings.
- Check the furling sections for external signs of damage

7.2 After each use

- Rinse off all parts with fresh water.

7.3 Annual maintenance

The following tasks and checks must be carried out within the scope of annual maintenance:

- Remove all contaminants and salt deposits.
- Check the forestay for damage.
- Check all screws for a firm fit
- Check the furling system for ease of movement
- Check the halyard swivel for ease of movement.
- Replace loop shackle
- Polish stainless steel parts.

8 Disassembly

⚠ Warning

Falling and vibrating components

Parts that are improperly secured may cause serious injury.

- The furling system may only be disassembled by qualified staff, such as a mast builder.
- Wear protective clothing, including safety helmet and work boots.
- Prior to disassembly, use appropriate means to secure any parts that may fall or vibrate.

⚠ Warning

Risk of crushing and shearing

- Never stick your finger into a threaded hole.

1. Disassemble the protective cage and the drum.
2. Remove the furling system from the mast and chain plate.
3. Detach the top cap.

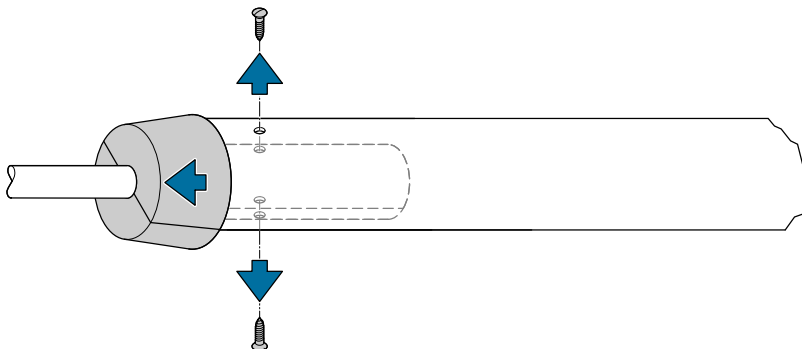

4. Remove the furling section adapter from the tack ring.
5. Loosen the furling section adapter from the furling section. Slide the furling section adapter onto the furling section.

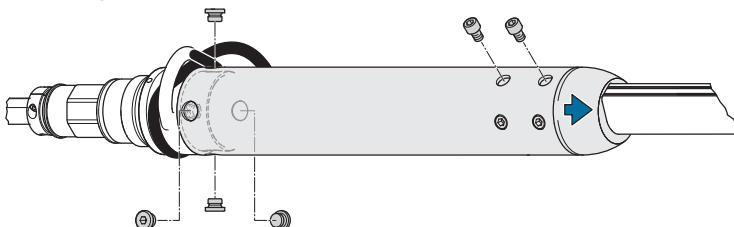

6. Remove both securing clips from the adjuster tube. Hold the forestay adapter using a spanner. Turn the adjuster tube clockwise until the holes for the bolts on the securing clip are just barely visible in the lengthwise holes of the adjuster tube.

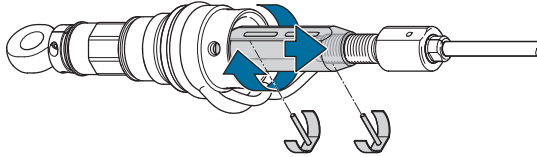

7. The further procedure depends on the type of forestay.

- For a rod forestay: Re-insert the securing clip that secures the drum axle in the adjuster tube. Then turn to completely remove the forestay adapter.

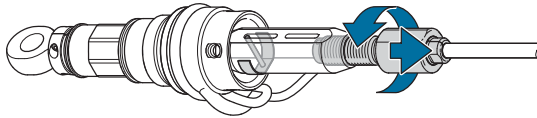

- For a wire forestay: Turn the adjuster tube further clockwise until the forestay adapter is free.

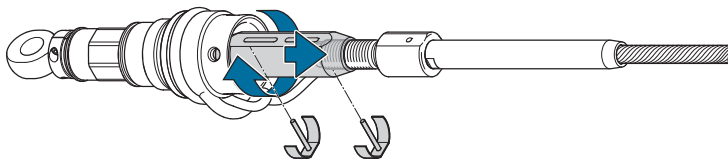

8. Remove the furling section adapter from the furling sections.

9. Remove the sail feeder.

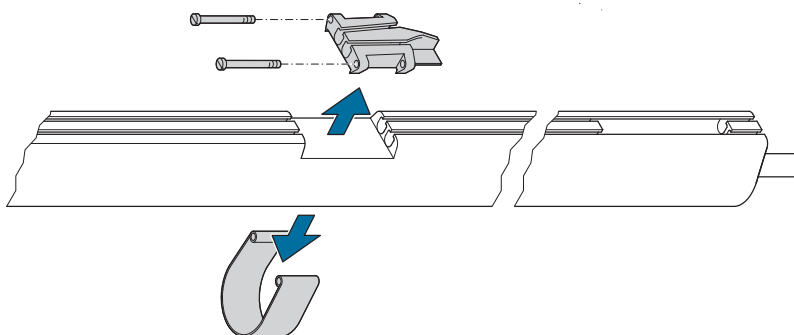

10. Remove the halyard swivel.

9 Storage

Notice

Risk of destruction of furling system by freezing water

In regions in which there is a danger of frost disassemble the furling system prior to storing for the winter.

Store the furling system parts in a dry room.

10 Disposal

Notice

Risk of damage to the environment

The halyard swivel and drum bearing unit contain lubricants that may cause serious environmental harm.

Dispose of the furling system parts in an environmentally friendly manner in accordance with local requirements.

Sort the furling system parts and dispose of them in accordance with the applicable local requirements.

11 Technical data

11.1 Dimensions

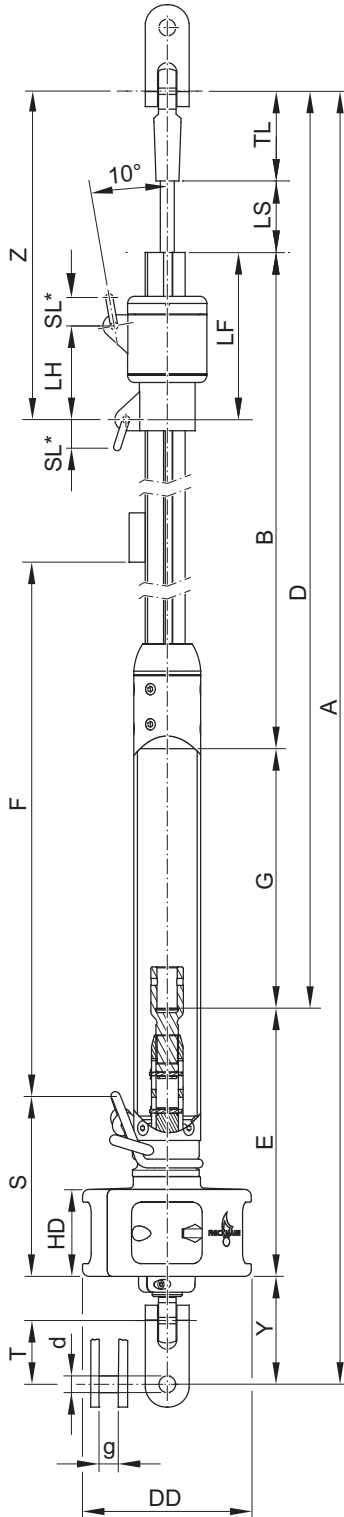

		MF-1						MF-2						MF-3	
halyard swivel / Fallenschlitten		FS-1			FS-2			FS-2		FS-3		FS-3		FS-4	
foil size / Profilgröße		R10			R20			R20		R30		R30		R40	
wire / Draht	[mm]	6	7	8	8	10	-	10	-	12	14	-	14	16	-
rod / Rod	[-]	-8	-10	-12	-12	-17	-22	-17	-22	-22	-30	-40	-30	-40	-48
T	pin - pin [mm]	64						72						93	
p	[mm]	12,7		15,9		19,1		19,1		22,2		25,4		28,6	
g	[mm]	17,5						24						28	
TL	[mm]	length of installed top terminal / Länge des installierten Topterminals													
LS	[mm]	70						70						120	
LF	[mm]	260			280			280		320		370		370	
LH	[mm]	135			145			145		180		200		200	
SL ***	[mm]	25			35			35		35		55		55	
Z	[mm]	dependent on TL / abhängig von TL													
S	[mm]	170						200						273	
F	[mm]	1055						1185						1378	
G *	rod / Rod [mm]	140						172						235	
	wire / Draht [mm]	138 (ø6; ø7; ø8); 126 (ø10)						159 (ø10); 164 (ø12); 152 (ø14)						218	
E *	rod / Rod [mm]	272						305						420	
	wire / Draht [mm]	274 (ø6; ø7; ø8); 286 (ø10)						318 (ø10); 313 (ø12); 325 (ø14)						437	
stroke / Hub	tumbuckle / Spanner [mm]	60						60						80	
Y **	min. [mm]	100						117						148	
adjustment / Verstellweg	toggle eye / Toggelaug [mm]	65						66						72	
DD	[mm]	167						193						260	
HD	[mm]	86						94						130	

* tumbuckle in mid position / Spanner in Mittelposition
 ** toggle eye fully in / Toggelaug ganz eingeschraubt
 *** Wichard D-shackle on FS-1, FS-2, FS-3, FS-4 / Wichard D-Schäkel an FS-1, FS-2, FS-3, FS-4

11.2 Furling section cross sections

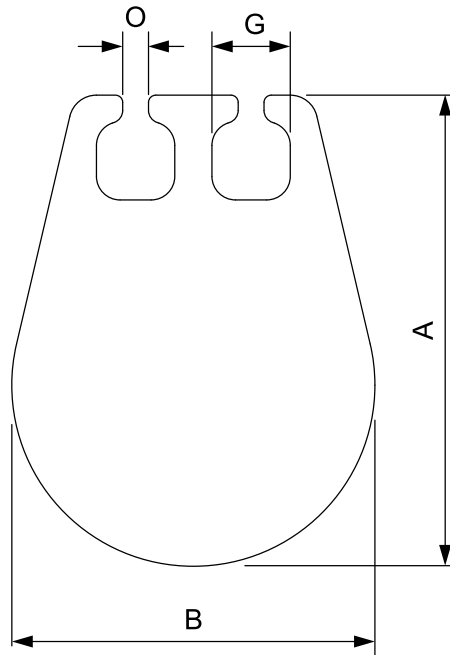

Furling section type	Groove	G [mm]	O [mm]	A [mm]	B [mm]
R10	Double	6.4	2.3	32.4	24.1
R20	Double	6.4	2.3	35.8	28.8
R30	Double	7.5	3.0	45.5	36.1
R40	Double	7.5	3.0	49.1	38.7
R50	Double	8.0	3.5	54.0	42.0

12 Index

- Adjusting the furling section length 14
- Assembly 13
- Caution 8
- Cold-headed rod end (rod head) 16, 19
- Design 11
- Direction of rotation 36
- Disassembly 43
- Disposal 46
- Drum 11
- Feeder section 25
- Forestay 11
- Forestay furling section 9, 40
- Function 12
- Furling 39
- Furling section adapter 11
- Furling section cross section 48
- Furling section reinforcement 25
- Halyard lead 31
- Halyard swivel 11
- Intended use 9
- Maintenance 42
- Mast head 30
- Mast toggle 30
- Notice 8
- Overview 11
- Protective cage 11
- Safety 9
- Sail feeder 11
- Sail UV protection 36
- Shortening
 - top furling section 14
 - top spacer 15
- Storage 45
- Swage terminal 23
- Swageless stud terminal 24
- Technical data 47
- Toggle 11
- Top bushing 11, 15
- Top cap 30
- Top furling section 15, 24
- Top spacer 15
- Top terminal 11
 - rod terminal 16
 - swage terminal 23
 - swageless stud terminal 24
 - wire terminal 23
- Typographical conventions 8
- Warning 8
- Wire pennant 39